

Standard thread dimensions

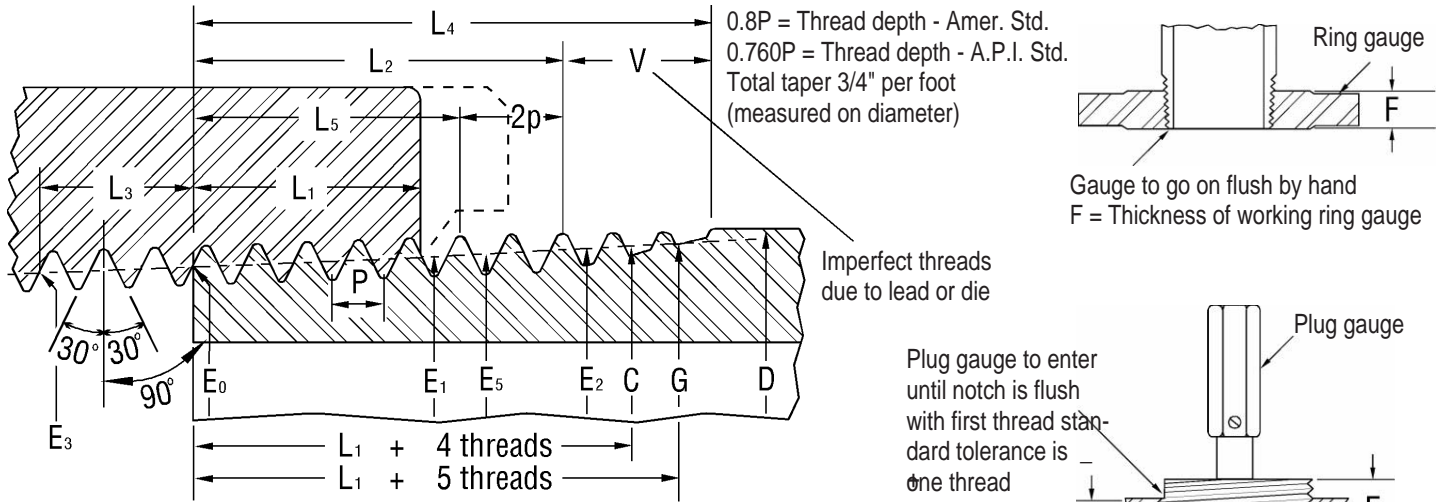

C = Straight pipe thread pitch diameter for locknut connections
 G = Minimum pitch diameter straight female locknut thread

Nominal pipe size	Outside diameter of pipe	Threads per inch	Pitch of thread	Pitch diameter at beginning of external threads	Handtight engagement		Effective thread external		Wrench make-up length for internal thread		Overall length external thread
					Length	Pitch diameter	Length	Pitch diameter	Length	Pitch diameter	
inches	D	N	P	E ₀	L ₁ †	E ₁	L ₂ ‡	E ₂	L ₃	E ₃	L ₄
1/8	.405	27	.0370	.3635	.180	.3748	.2639	.3800	.1111	.3566	.3924
1/4	.540	18	.0556	.4774	.200	.4899	.4018	.5025	.1667	.4670	.5946
3/8	.675	18	.0556	.6120	.240	.6270	.4078	.6375	.1667	.6016	.6006
1/2	.840	14	.0714	.7584	.320	.7784	.5337	.7918	.2143	.7450	.7815
3/4	1.050	14	.0714	.9677	.339	.9889	.5457	1.0018	.2143	.9543	.7935
1	1.315	11-1/2	.0870	1.2136	.400	1.2386	.6828	1.2563	.2609	1.1973	.9845
1-1/4	1.660	11-1/2	.0870	1.5571	.420	1.5834	.7068	1.6013	.2609	1.5408	1.0085
1-1/2	1.900	11-1/2	.0870	1.7961	.420	1.8223	.7235	1.8413	.2609	1.7798	1.0252
2	2.375	11-1/2	.0870	2.2690	.436	2.2963	.7565	2.3163	.2609	2.2527	1.0582
2-1/2	2.875	8	.1250	2.7195	.682	2.7622	1.1375	2.7906	.2500	2.7039	1.5712
3	3.500	8	.1250	3.3406	.766	3.3885	1.2000	3.4156	.2500	3.3250	1.6337
3-1/2	4.000	8	.1250	3.8375	.821	3.8880	1.2500	3.9156	.2500	3.8219	1.6837
4	4.500	8	.1250	4.3344	.844	4.3871	1.3000	4.4156	.2500	4.3188	1.7337
* 4-1/2	5.000	8	.1250	4.8313	.875	4.8859	1.3500	4.8418
5	5.563	8	.1250	5.3907	.937	5.4493	1.4063	5.4786	.2500	5.3751	1.8400
6	6.625	8	.1250	6.4461	.958	6.5060	1.5125	6.5406	.2500	6.4305	1.9462
* 7	7.625	8	.1250	7.4398	1.000	7.5023	1.6125	7.4524
8	8.625	8	.1250	8.4336	1.063	8.5000	1.7125	8.5406	.2500	8.4180	2.1462
* 9	9.625	8	.1250	9.4273	1.130	9.4980	1.8125	9.4415
10	10.750	8	.1250	10.5453	1.210	10.6209	1.9250	10.6656	.2500	10.5297	2.3587
* 11	11.750	8	.1250	11.5391	1.285	11.6194	2.0250	11.5549
12	12.750	8	.1250	12.5328	1.360	12.6178	2.1250	12.6656	.2500	12.5172	2.5587
14	14.000	8	.1250	13.7750	1.562	13.8726	2.2500	13.9156	.2500	13.7594	2.6837
* 15	15.000	8	.1250	14.7688	1.687	14.8742	2.3500	14.7872
16	16.000	8	.1250	15.7625	1.812	15.8758	2.4500	15.9156	.2500	15.7469	2.8837
* 17	17.000	8	.1250	16.7563	1.900	16.8750	2.5500	16.7762
18	18.000	8	.1250	17.7500	2.000	17.8750	2.6500	17.9156	.2500	17.7344	3.0837
20	20.000	8	.1250	19.7375	2.125	19.8703	2.8500	19.9156	.2500	19.7219	3.2837
* 22	22.000	8	.1250	21.7250	2.250	21.8656	3.0500	21.7488
24	24.000	8	.1250	23.7125	2.375	23.8609	3.2500	23.9156	.2500	23.6969	3.6837

Data per American Standard B2.1-1945 (For Taper Pipe Threads) and API Standard 6-A (for line pipe threads).

* Sizes discontinued in American Standards listed for reference only.

† Also length of plug gauge.

‡ Length of ring gauge and length from gauging notch to small end of plug gauge.

The American Standard Pipe Thread and the API Standard Line Pipe Thread are interchangeable.

Reprinted by permission from Catalog No. 55, Ladish Co.