

# Technical Data Sheet

CitcoWater.com



CHEMICAL  
SOLUTIONS



## PRO FLO

Vapor Distribution System

### ProFlo VDS - Vapor Distribution System Combating Airborne Odor

Introduction: Odor control is one of the most serious issues facing industrial and municipal personnel today. CITCO Water believes that most odor control technologies only focus on covering up or masking odors without addressing the odorous compound source. CITCO Water has worked in the industrial manufacturing and wastewater treatment industry for over 24 years. Based on this extensive industry experience, our Chemical Feed Systems division and staff developed both the ProFlo family of systems and ROX-92 Vapor Odor Absorption Chemistry feed technology to specifically target odorous compounds that reach the airborne state for industry and municipal needs.



### Benefits



#### No Chemical Fallout

Fogging or misting has a fall out percentage of chemical, vapor does not.



#### No Wet Mist Or Freezing Issues

ROX-92 will not freeze in cold weather scenarios and will not cause nozzle to clog.



#### Custom Designed Odor Control System

Based on the specific needs of your industrial or municipal odor control needs.



#### Available For Purchase Or Rental

Effective odor control all year but also works effectively for seasonal shifts in airborne odor.

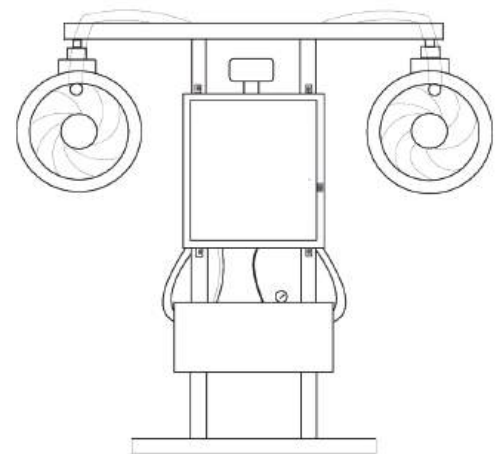

info@CitcoWater.com  
customerservice@CitcoWater.com  
800.999.3484

# CITCO WATER

# Technical Data Sheet

CitcoWater.com



CHEMICAL  
SOLUTIONS



## ProFlo VDS - Airborne Odor Mitigation For Industrial And Municipal Applications

Details: The ProFlo VDS is an odor control system used for outdoor areas on perimeter fencing, concrete containment walls, and in a number of industrial odor control scenarios. It can be adapted and sized for each individual application. The ProFlo VDS uses 2 regenerative blowers and a vapor chamber to distribute vapor charged air throughout a main supply line. The main supply line is mounted around the structure and/or perimeter fencing with 3/16" orifices to allow charged vapor to feed out. CITCO Water's ROX-92 is fed into the main chamber via a metering pump for accurate dosing. The main chamber utilizes temperature and pressure to change liquid into vapor form while ROX-92 absorbs nuisance odors such as hydrogen sulfide, ammonia, and mercaptans making the ProFlo VDS highly effective in outdoor odor control scenarios.

### Additional Features

- Durable Stainless Steel Construction
- Designed to Withstand Harsh Odor
- Fiberglass Enclosure with Regenerative Blower
- Vapor Chamber
- Available for Rental or Purchase
- Utilizes CITCO Water's Proprietary Chemistry: ROX-92
- Chemical Metering Pump
- Mobile Units are Easily Transported
- Installed and Maintained by CITCO Water Systems Technicians
- Highly Effective Year Round, Seasonally, or for One-Time Event



# Technical Data Sheet

CitcoWater.com



CHEMICAL  
SOLUTIONS



## PRO FLO

*Vapor Distribution System*

### Field Installation Gallery

A rendering facility was receiving community odor complaints until they installed a ProFlo VDS utilizing ROX-92.

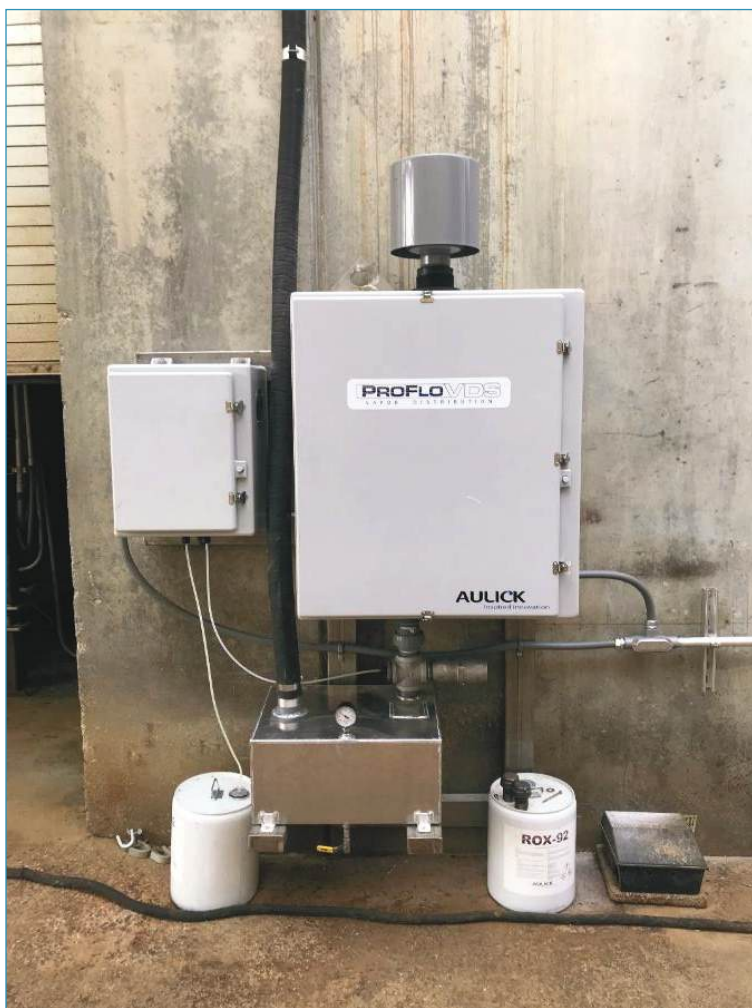

Rendering  
Plant  
Scrubber -  
South  
Exhaust

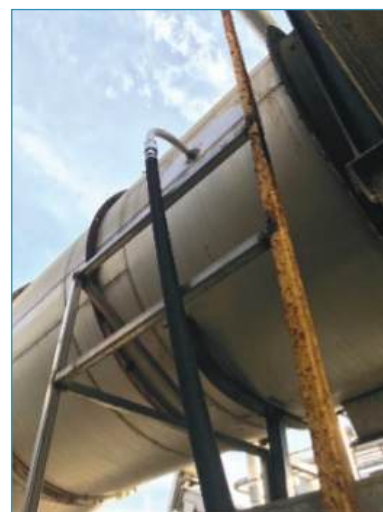

Rendering  
Plant  
Scrubber -  
North Exhaust



info@CitcoWater.com  
customerservice@CitcoWater.com  
800.999.3484

# CITCO WATER



# Technical Data Sheet

CitcoWater.com



CHEMICAL  
SOLUTIONS



## Field Installation Gallery

A food processing plant was receiving odor complaints from local businesses as well as threats of fines from the City. They installed a ProFlo VDS feeding ROX-92 and were able to mitigate their odor issues.



Perimeter  
Fence Line  
Distribution  
Piping

